

CAST IRON GLOBE VALVES

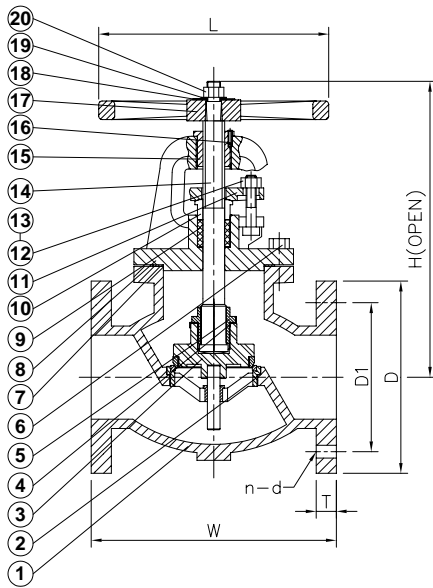

SERIES 560

CLASS 125, FLANGED ENDS (TO ANSI B16.1), BOLTED BONNET, FACE-TO-FACE DIMENSIONS TO ANSI B16.10, MSS SP-85 DESIGNED, SIZE:2"-12".



MATERIALS LIST:

NO.	PART	SPECIFICATION
1	BODY	ASTM A126 CLASS B
2	SEAT RING	ASTM B62
3	DISC	ASTM A126 CLASS B
4	GASKET	ASTM B16
5	SWIVEL NUT	ASTM B16
6	BOLT	ASTM A307-B
7	BODY GASKET	NON ASBESTOS
8	BONNET	ASTM A126 CLASS B
9	PACKING	NON ASBESTOS
10	PACKING GLAND	ASTM B584
11	GLAND FOLLOWER	ASTM A536 65-45-12
12	GLAND BOLTS	ASTM A307-B
13	NUTS	ASTM A307-B
14	STEM	ASTM B16
15	YOKE BUSHING	ASTM B62
16	SCREW	ASTM A307-B
17	HANDWHEEL	ASTM A126 CLASS B
18	IDENTIFICATION PLATE	ALUMINUM
19	WASHER	ASTM A307-B
20	NUTS	ASTM A307-B

DIMENSIONS:

SIZE		W		L		H(OOPEN)		D		D1		T		n-d
IN	MM	IN	MM	IN	MM	IN	MM	IN	MM	IN	MM	IN	MM	
2"	50	8.00	203	7	178	10.19	259	6.00	152	4.75	121.0	0.63	15.9	4-19
2-1/2"	65	8.50	216	7	178	11.81	300	7.00	178	5.50	140.0	0.69	17.5	4-19
3"	80	9.50	241	8	203	12.50	318	7.50	191	6.00	152.5	0.75	19.0	4-19
4"	100	11.50	292	10	254	15.81	402	9.00	229	7.50	190.5	0.94	23.8	8-19
5"	125	13.00	330	12	305	16.50	419	10.00	254	8.50	215.9	0.94	23.8	8-22.2
6"	150	14.00	356	12	305	18.88	479	11.00	279	9.50	241.3	1.00	25.4	8-22.2
8"	200	19.50	495	13.7	347	21.13	537	13.50	343	11.75	298.5	1.13	28.6	8-22.2
10"	250	24.50	622	16	406	25.19	640	16.00	406	14.50	368.3	1.19	30.2	12-25.4
12"	300	27.50	699	18	457	28.88	733	19.00	483	17.00	432.0	1.25	31.8	12-25.4

DUE TO CONTINUOUS DEVELOPMENT OF OUR PRODUCTS, WE RESERVE THE RIGHT TO MODIFY OUR PRODUCT DESIGN OR CONSTRUCTION WITHOUT PRIOR NOTICE.